

The Dissociation of BH_3CO into BH_3 and CO ¹

T. P. Fehlner and W. S. Koski

Contribution from the Department of Chemistry, The Johns Hopkins University, Baltimore, Maryland 21218. Received July 23, 1964

The reaction $BH_3CO \rightarrow BH_3 + CO$ has been studied in a low pressure flow system using a special mass spectrometer. The reaction was found to be first order in BH_3CO and homogeneous. The rate constant for the unimolecular decomposition is 19 sec.^{-1} at $400^\circ K$. and was independent of the total pressure in the region examined. The bond dissociation energy $D(H_3B-CO)$ is estimated to be $23.1 \pm 2 \text{ kcal./mole}$. This yields $D(H_3B-BH_3) = 37.1 \pm 4 \text{ kcal./mole}$.

Introduction

In a recent note² we reported the mass spectrometric detection of BH_3 and BH_2 in the thermal decomposition of diborane. As was mentioned, examination of BH_3CO pyrolysis in the same apparatus indicated that this compound was decomposing by a single reaction, namely



The more detailed examination of reaction 1, reported herein, was undertaken because systems of this simplicity are rather rare. Perhaps more important was the possibility that by measuring the rate of (1) a good estimate of the bond dissociation energy $D(H_3B-CO)$ could be obtained.

Equipment

The mass spectrometer used in this study was designed and constructed specifically for the detection of unstable species according to the principles adequately described by previous workers.³⁻⁸ In essence, radicals are detected with this method by using low energy electrons so that the observed current of the radical positive ion arises almost entirely from the ionization of the corresponding radical, and the contribution by dissociative ionization of molecules is small.

The schematic drawing shown in Figure 1 indicates the major features of this 90° sector, 7-cm. radius instrument. To increase the sensitivity, a quadrupole ion lens was used. The application of this lens to a mass spectrometer has been described by Giese,⁹ and the details of an actual source have been given by Kinzer and Carr.¹⁰ This lens was designed according

to the article by Lu and Carr¹¹ such that the ions left the ionizing region through a 0.190×0.115 in. rectangular hole. Also for high sensitivity, relatively wide entrance and exit slits of 0.015 and 0.040 in., respectively, were used. Electron multiplier detection further increased the sensitivity. The multiplier used was a Dumont SP 172 having 14 Ag-Mg stages. The gain was about 10^4 to 10^5 for operation at 165 v. per stage. The resolution of the instrument was low, $M/\Delta M$ being about 40. Electrostatic focusing was used for convenience,¹² and consequently multiplier discrimination was high. However, as only changes in a single mass peak were measured, this was not a problem. An estimate of the sensitivity is 10^{-10} amp./ μ pressure (calculated) in the furnace at an ionizing voltage of 70 v., trap current of $1 \mu a.$, and 80 v. per stage. It was about 5×10^{-8} amp./ μ at 165 v. per stage. Ten divisions, corresponding to 10^{-13} amp. could easily be measured. The relative sensitivities for radical detection by the low voltage method may be estimated by the equations of Robertson.⁷ The emission regulator used has been described by Solomon and Caton.¹³

A detailed drawing of the ion source region is shown in Figure 2 with the various parts labeled in the caption. Several features should be noted. First, the accelerating rings and quadrupole lens assembly were mounted separately from the electron gun assembly (see also Figure 1). Besides allowing the source to be easily replaced, it left the ionizing region open. This minimizes wall collisions and maximizes the pumping speed at the furnace exit. The electron gun was installed so that the filament was directly over the 2-in. pumping lead. A small 3-cm. long, 1-mm. i.d. tubular quartz furnace is mounted with its exit close to the electron beam. The furnace was constructed as has been described in detail by Lossing¹⁴ with tantalum elements. It will be noted that use of the quadrupole lens allows a much larger portion of the furnace efflux to be sampled than with the normal slit. The heated region was about 25 mm. long. The furnace temperature was measured with a platinum-platinum-rhodium (90:10) 0.0001-in. diameter thermocouple placed in the positions indicated at different times. The position had no effect on the results. The ion lens and the electron gun assembly were unheated except for the filament itself. The temperature of the furnace with the filament on and the furnace off was 55° (central position). The reactant gas is admitted to the furnace through a variable leak, and the mixture flows through the furnace with a contact time of about 3 msec. The reactor pressure and dimensions were such that molecular

(1) This work was done under the auspices of the United States Atomic Energy Commission.

(2) T. P. Fehlner and W. S. Koski, *J. Am. Chem. Soc.*, **86**, 2733 (1964).

(3) G. C. Eltenton, *J. Chem. Phys.*, **10**, 403 (1942); *ibid.*, **15**, 455 (1947).

(4) J. A. Hipple and D. P. Stevenson, *Phys. Rev.*, **63**, 121 (1943).

(5) F. P. Lossing, *Ann. N. Y. Acad. Sci.*, **67**, 499 (1957).

(6) S. N. Foner and R. L. Hudson, *J. Chem. Phys.*, **21**, 1608 (1953); *ibid.*, **23**, 1364 (1955).

(7) A. J. B. Robertson, "Mass Spectrometry," John Wiley and Sons, Inc., New York, N. Y., 1954.

(8) M. G. Inghram and J. Drowart, "Proceedings of an International Symposium on High Temperature Technology," McGraw-Hill Book Co., Inc., New York, N. Y., 1960.

(9) C. F. Giese, *Rev. Sci. Instr.*, **30**, 260 (1959).

(10) E. T. Kinzer and H. E. Carr, *ibid.*, **30**, 1132 (1959).

(11) C. S. Lu and H. E. Carr, *ibid.*, **33**, 823 (1962).

(12) Considerations of maximum portability and versatility were included in the design.

(13) A. K. Solomon and D. C. Caton, *Rev. Sci. Instr.*, **23**, 757 (1952).

(14) F. P. Lossing and J. B. Desousa in "Advances in Mass Spectrometry," J. D. Waldron, Ed., Pergamon Press, New York, N. Y., 1959.

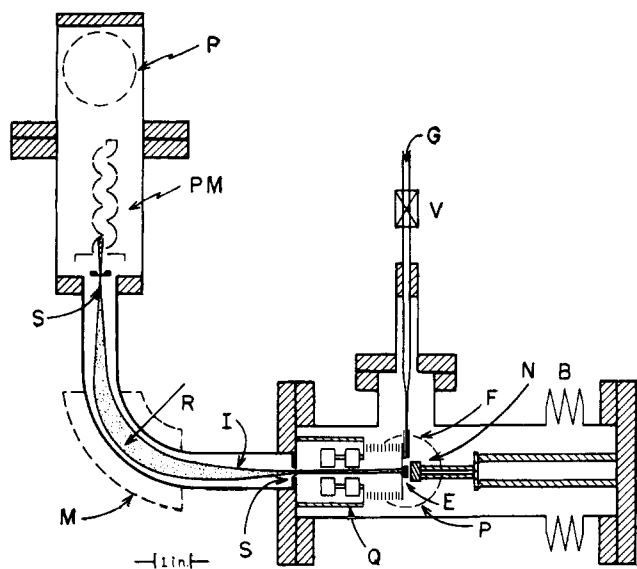

Figure 1. Schematic drawing of the mass spectrometer: B, stainless steel bellows; E, electron beam; F, quartz furnace, 1 mm. i.d.; G, reactant gas inlet; I, ion beam; M, magnet pole face, Indiana General; P, 2-in. pumping leads (Varian "Vac Ion," 75 l./sec.; Consolidated MHG40, 40 l./sec. with BC baffle at 77°K.); PM, electron multiplier (Dumont SP 172), 14 stages; Q, quadrupole lens; R, radius of curvature, 7 cm.; S, entrance and exit slits, 0.014 in. and 0.040 in. wide, respectively; V, variable leak, Granville-Phillips; N, electron gun mount.

flow was taking place.¹⁵ The furnace pressure was calculated¹⁵ for the first heated point in the furnace, and as this is a flow system there is a pressure gradient in the furnace. Differential pumping was used, and, with a calculated pressure of 5μ in the furnace, the pressure outside the ionizing region, as measured by an ion gauge connected by 0.75-in. tubing on a flange directly above the pumping lead in Figure 1, is 5×10^{-7} torr, while that in the analyzer tube and electron multiplier section is 5×10^{-8} torr.

The borane carbonyl was prepared as described by Burg.¹⁶ It was purified by vacuum fractionation, the purity being determined mass spectrometrically. The concentrations of diborane, tetraborane, and the pentaboranes were monitored using $m/e = 25, 50,$ and $64,$ respectively. Diborane was less than 3% while the higher boranes were absent. The diluent gases were Matheson reagent grade.

Results

Identification of Products. The major ions observed in the mass spectrum of BH_3CO at an ionizing voltage of 70 v. were $\text{BH}_3\text{CO}^+, \text{BH}_2\text{CO}^+, \text{BHCO}^+, \text{BCO}^+, \text{CO}^+, \text{O}^+, \text{BH}_3^+, \text{BH}_2^+, \text{BH}^+, \text{C}^+,$ and H_2^+ , with some very minor peaks attributed to H_2BC^+ ions. The most intense ion peak was $m/e = 40$; however, because of the multiplier discrimination mentioned above, the relative intensities are not too meaningful.

These ions were identified as follows. The m/e values were determined by comparison with the known background of water, nitrogen, oxygen, carbon dioxide, and some hydrocarbons. The ratio of the intensity of $m/e = 39$ (corrected for $^{10}\text{BHCO}^+$) to $m/e = 38$ was

(15) S. Dushman, "Scientific Foundations of Vacuum Technique," 2nd Ed., John Wiley and Sons, Inc., New York, N. Y., 1962.

(16) A. B. Burg, *J. Am. Chem. Soc.*, **59**, 780 (1937).

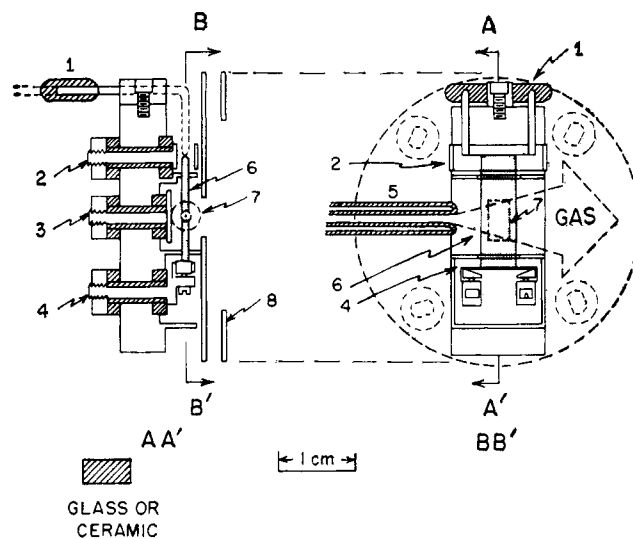

Figure 2. Ion source assembly (constructed of nonmagnetic stainless steel and nichrome V except where indicated otherwise): 1, filament assembly (filament wire, 0.006-in. diameter tungsten); 2, electron focus electrode (J. L. Peters, *Rev. Sci. Instr.*, **30**, 1093 (1959)); 3, repeller plate; 4, trap (platinum ribbon that may be electrically cleaned after pump down); 5, front portion of quartz tubular furnace (two thermocouple positions shown; tantalum heating element fits in annular space between outer and inner tubes); 6, electron beam (entrance and exit slit widths are 0.045 and 0.030 in., respectively); 7, ion exit hole in first place of the lens assembly (0.190×0.115 in.); 8, first accelerating ring in lens assembly.

equal to the $^{11}\text{B}-^{10}\text{B}$ natural abundance. These ions were also observed to depend on the leak setting.

The products produced by activating the furnace were then identified. Ion peaks characteristic of the stable boron hydrides mentioned in the Experimental section were monitored, but none was found being produced. Unstable products were sought by examining the intensity of the ion peak of interest as a function of the furnace temperature at an ion voltage below the appearance potential of the ion produced by dissociative ionization of BH_3CO . The $\text{CO}^+, \text{BH}_3^+, \text{BH}_2^+,$ and H_2^+ ions were examined in this manner. Only BH_3^+ and CO^+ showed the characteristic increase with furnace temperatures (see ref. 2) indicating the products are BH_3 and CO . The presence of these species was confirmed by rough appearance potential measurements. It should be noted carefully that BH_2 could be detected from diborane with the same furnace, under identical conditions and on the same day. Apparently then, the decomposition of BH_3CO into BH_3 and CO is being observed.

A critical question here is whether the products originate in the furnace or elsewhere. Perhaps the strongest evidence that decomposition in the furnace produces the products found results from the observation that changing only the inner surface of the reactor had a remarkable effect on BH_2 formation from diborane but unaffected BH_3 production (see below for details). Secondly, the observed ion signal of $m/e = 40$ with argon flowing through the furnace noticeably decreased for measured furnace temperatures over about 450°K. "Hot" molecules from the furnace would be in the ionizing region less time than "cold" molecules and thus would have less chance of being ionized (also see below). The "dewar" construction

of the furnace limits reaction with the furnace elements. It is very unlikely that the comparatively large metal source elements could have been heated by the physically separated glass furnace. The proximity of the furnace exit to the electron beam and the use of the quadrupole lens which allows a large portion of the furnace efflux to be sampled are also relevant. The products BH_3 and CO then are resulting from decomposition of BH_3CO in the furnace.

Kinetic Measurements. The reaction was followed by observing the destruction of BH_3CO as reflected by the decrease in the $m/e = 40$ peak ($^{11}\text{BHCO}^+$, $^{10}\text{BH}_2\text{CO}^+$) for which the leak independent background intensity was negligible. An ionizing voltage of 70 v. was used for stability. The following experimental reasons made it necessary to monitor the extent of decomposition in this manner in spite of the fact that theoretically for low conversions more accurate measurements could be made by following the formation of products rather than the destruction of reactants. The most important consideration is that measurement of product formation would have involved calculation of partial pressures which would have necessitated elimination of the effect of residual gas (see below) and careful calibration. Also, measurements either had to be made at low voltages where parent ion fragmentation was negligible or at 70 v. where the contribution due to fragmentation would have to be subtracted. Both would increase the error substantially.

The first-order rate constant was calculated according to Harris¹⁷ using the following equation which takes into account the "volume effect"¹⁸

$$k_1 = \frac{V_0}{F} [-4.6 (\log I_2/I_1 - (1 - I_2/I_1))]$$

where k_1 is the rate constant for reaction 1, F is the conductance of the furnace (conditions of molecular flow¹⁵), V_0 is the reactor volume, and I_2 and I_1 are the ion currents of $m/e = 40$ with the furnace on and off, respectively.¹⁹ Before the results are given, however, several possible spurious effects must be examined.

First, when the reactant gas is stable with respect to wall collisions, a residual pressure of the gas will be built up to a steady-state concentration in the ionizing region. This concentration is a function of the rate of efflux from the furnace and the pumping speed at the ionizing region. The ion current measured, then, will be partly due to beam molecules and residual molecules. As it is the beam molecules that are of interest, the effect of residual molecules must be examined. An estimate of the actual ratio of beam molecules to residual molecules in the ionizing region was obtained from the ratio of BH_3 to CO . BH_3 is probably not stable with respect to wall collisions while CO is. The ion current due to the former would be proportional to the number of beam molecules, while the latter would be proportional to the sum of beam and residual molecules. Assuming equal cross sections

(17) G. M. Harris, *J. Phys. Colloid Chem.*, **51**, 505 (1947).

(18) The "diffusion effect" is considered negligible as the effective displacement to the flow is about 30 times larger than that due to diffusion.

(19) The amount of reaction occurring at room temperature in the furnace would introduce a correction of less than 1% in a rate constant measured at 390°K.

and correcting for differences in electron energy over threshold gave $\text{BH}_3/\text{CO} = 0.2$.

However, it is not necessary to correct the measured ion currents in this case for the following reason. The pumping speed for BH_3CO will be independent of the number of BH_3CO molecules in the beam, and thus the steady-state ratio of beam molecules to residual molecules will be independent of changes in the number of beam molecules. If then, the number of beam molecules decreases a small amount because of BH_3CO decomposition in the furnace, the number of residual molecules will decrease a proportionate amount at steady-state conditions. Consequently, as the ratio of ion currents, I_2/I_1 , is being used, the effect of residual gas cancels and its only consequence is to contribute to the error of the measurement.

These considerations show why, with argon in the furnace, heating to low temperatures (*ca.* 400°K.) did not decrease the Ar^+ signal noticeably. Using the estimate of residual gas above, one would expect a decrease of less than 2%.

Next, the possibility of molecules passing through the reactor with no collisions exists at these low pressures. The number of unheated molecules was estimated by observing the amount of BH_3CO destroyed at a reactor temperature such that most collisions would be effective. It was found that over 93% of BH_3CO could be destroyed at a measured reactor temperature of about 525°K. This effect appears to be small and for the purposes of this study it was not necessary to correct for it.

The calculated k values for various conditions are given in Table I. As may be seen, the calculated first-order rate constant is independent of the BH_3CO partial pressure (Table I, A) and CO partial pressure (Table I, B).²⁰ This was confirmed by an examination of BH_3 production at higher temperatures. It was found that the amount of BH_3 detected was proportional only to the partial pressure of BH_3CO in the reacting gas. The effect of total pressure was carefully checked over the available pressure range in a separate experiment. Although the absolute pressure of the reactor was calculated, the relative pressures are known fairly accurately (*ca.* 10%), as they could be calculated from the relative peak heights. In this particular experiment, they are known to within 5%. A higher temperature was also used to improve the analytical precision, which in this case was estimated to be 25%.²¹ No increase in the rate constant with total pressure is observed (Table I, C).

Although the reaction is homogeneous at higher pressures,²² a surface reaction could make a significant contribution at these low pressures. The reactor proper also had a thin coating of boron from some tetraborane experiments which would perhaps enhance the above possibility. The following indicates that this is not the case. In studies of the pyrolysis of hydrocarbons it has been noted that treatment of the carbonaceous surface deposit with oxygen has a large effect on the rate constant.²³ If surface reactions

(20) Generally runs were made with CO present as this inhibited BH_3CO decomposition in the reactant gas reservoir.

(21) S. W. Benson, "The Foundations of Chemical Kinetics," McGraw-Hill Book Co., Inc., New York, N. Y., 1960.

(22) M. E. Garabedian and S. W. Benson, *J. Am. Chem. Soc.*, **86**, 176 (1964).

Table I

	Run	$P_{\text{total}} \times 10^3$, torr	Mole fraction of BH_3CO	Mole fraction of CO	Diluent gas	Temp., °K.	V_0/F , msec.	I_2/I_1	k_1 , sec. ⁻¹	E_A , kcal./mole	
A	Vary BH_3CO partial pressure	5173	22	0.045	0.0	Ne	408	3.18	0.952	15.1	23.8
		5252	12	0.083	0.14	Kr	400	3.25	0.955	14.5	23.3
		5253	12	0.083	0.14	Kr	401	3.21	0.917	28.4	22.8
		5254	12	0.083	0.14	Kr	402	3.21	0.923	25.8	23.0
		5183	13	0.11	0.08	Ne	406	3.20	0.957	13.8	23.7
		5151	2.5	0.56	0.0	Ne	395	3.26	0.948	16.2	23.0
B	Vary CO partial pressure	5154	2.5	0.56	0.0	Ne	400	3.25	0.943	19.1	23.1
		5152	2.5	0.56	0.0	Ne	399	3.22	0.940	18.3	23.1
		5172	22	0.045	0.0	Ne	408	3.18	0.923	26.1	23.3
		5213	19	0.065	0.042	Xe	388	3.27	0.963	12.5	22.7
		5214	19	0.065	0.042	Xe	388	3.27	0.920	26.0	22.2
		5163	20	0.050	0.050	Ne	396	3.26	0.931	22.5	22.7
		5164	20	0.050	0.050	Ne	396	3.26	0.957	14.2	23.1
		5165	20	0.050	0.050	Ne	402	3.21	0.957	14.3	23.4
		6011	4	0.060	0.31	Xe	400	3.25	0.930	23.4	22.9
		C	Vary total pressure	6019	0.945	0.06	0.31	Xe	462	3.00	0.834
6015	6.32			0.06	0.31	Xe	462	3.00	0.843	60.4	..
6016	6.32			0.06	0.31	Xe	462	3.00	0.812	76.3	..
6017	12.0			0.06	0.31	Xe	462	3.00	0.834	65.3	..
D	O_2 treatment	6034	12	0.06	0.10	Xe	410	3.17	0.924	25.2	23.4
		6035	12	0.06	0.10	Xe	402	3.21	0.967	11.2	23.6
E	Change in surface	6083	11	0.18	0.12	Xe	405	3.20	0.888	39.5	22.8
		6084	11	0.18	0.12	Xe	407	3.20	0.903	34.0	23.0

were occurring in BH_3CO decomposition, one might expect the same phenomenon. But after oxygen was passed through the furnace at 700°K . for 3 hr., the measured rate constant remained the same as before the treatment (Table I, D). The surface itself was changed by coating the inside of the reactor with about 0.5 mg. of Al_2O_3 having a surface area of 100 to 200 m^2/g .²⁴ Once again no significant change in the rate constant was observed (Table I, E). This change of surface also did not affect the production of BH_3 from BH_3CO or B_2H_6 . It did, however, greatly inhibit the formation of BH_2 from B_2H_6 indicating that this reaction may be heterogeneous. In this light, it is not unreasonable to suppose that BH_3CO is decomposing homogeneously.

Bond Dissociation Energy. A recent reanalysis of the kinetic data on the thermal decomposition of BH_3CO in a "normal" system, where several reactions in addition to (1) occur, suggested a reasonable upper limit on $D(\text{H}_3\text{B}-\text{CO})$ of 23.7 kcal./mole.²²

In the course of this study, a rough measurement of the appearance potential of BH_3^+ from BH_3CO along with the ionization potential of BH_3 ³ gave a value of $D(\text{H}_3\text{B}-\text{CO}) = 21 \pm 9$ kcal./mole. Experimental conditions did not allow a more accurate measurement.

As mentioned above, the heat of reaction of (1) would yield $D(\text{H}_3\text{B}-\text{CO})$. This heat of reaction is equal to the difference in the activation energy of (1) and the activation energy for the recombination. As there is considerable evidence that the latter is very small in reactions of this type,²⁵ a measurement of the activation energy of (1) would provide a good estimate of $D(\text{H}_3\text{B}-\text{CO})$.

The temperature variation of the rate constant was measured, and an activation energy plot made. How-

(23) F. O. Rice and K. F. Herzfeld, *J. Phys. Colloid Chem.*, **55**, 975 (1951).

(24) Supplied by Professor R. J. Kokes.

(25) M. Szwarc, *Chem. Rev.*, **47**, 75 (1950).

ever, instead of being linear, the slope of the curve increased with increasing temperature in an interval from 360 to 500°K . An accurate measurement of the slope at low temperatures and over a small temperature interval was precluded by the scatter in the rate data. Three possibilities could explain this curvature: a complex reaction, a complex surface effect, or failure to attain temperature equilibrium. In light of the discussion above, the first two may be regarded as unlikely. At these low pressures then, it appears that the reacting gas is not heated to the temperature measured by the thermocouple and that this discrepancy increases with increasing temperature. Unfortunately then, one of the very factors that confine the system to reaction 1 precludes an activation energy measurement without a large error.

It has been pointed out by Szwarc,²⁵ however, that a good estimate of the activation energy could be obtained from an estimate of the rate constant at a low temperature and low conversion provided the frequency factor is known. The kinetic study mentioned above²² indicates that the frequency factor for (1) lies between $10^{13.4}$ and $10^{14.4}$. A mean value of $10^{13.9}$ yields the activation energies listed in Table I with an average value of 23.1 kcal./mole.

This value is subject to several sources of error whose magnitude may be estimated as follows. The limits on the frequency factor would give $\Delta E_A = \pm 0.9$ kcal./mole. At a furnace temperature of 400°K ., it is believed that the maximum error in the measured temperature difference is 30% (20°) which would give $\Delta E_A = \pm 0.7$ kcal./mole. Finally, an error in measuring the effective length of the furnace and calculating the contact time thereby causing an error in k of 100% would yield $\Delta E_A = \pm 0.3$ kcal./mole.²⁶ The activation energy then is $E_A = 23.1 \pm 2$ kcal./mole.

(26) Most of these errors would be expected to cancel when two different determinations of k are compared. For this reason the conclusions on the order, pressure dependence, and homogeneity arrived at above are valid.

It may be concluded that a good estimate of $D(\text{H}_3\text{B}-\text{CO})$ is 23.1 ± 2 kcal./mole. This value, when combined with Burg's equilibrium data²⁷ gives $D(\text{H}_3\text{B}-\text{B}-\text{BH}_3) = 37.1 \pm 4$ kcal./mole. The value of 39 ± 9 kcal./mole obtained by electron impact measurements is in good agreement as is the value estimated recently.²²

Although the above dissociation energies appear to be compatible to within experimental error with the best previous estimates of these energies and with independent electron impact measurements, recently

(27) A. B. Burg, *J. Am. Chem. Soc.*, **74**, 3482 (1952).

Baylis, Pressley, Sinke, and Stafford,²⁸ using a Knudsen-type cell coupled with a mass spectrometer, studied the dissociation of diborane and conclude that $D(\text{BH}_3\text{BH}_3) \geq 55$ kcal./mole, a surprisingly high value. The reasons for this disagreement are not clear to us and probably will have to be resolved by further work.

Acknowledgments. The authors wish to acknowledge the helpful suggestions of Professors P. H. Emmett, J. W. Gryder, and R. J. Kokes on the surface effects.

(28) A. B. Baylis, G. A. Pressley, E. J. Sinke, and F. E. Stafford, presented at the 148th National Meeting of the American Chemical Society, Chicago, Ill., Sept. 1, 1964.

Polymerization of Liquid Sulfur

J. A. Poulis,^{1a} C. H. Massen,^{1a} A. Eisenberg,^{1b} and A. V. Tobolsky^{1c}

Contribution from the Physics Department, Technological University, Eindhoven, the Netherlands, the Department of Chemistry, University of California at Los Angeles, Los Angeles, California, and the Department of Chemistry, Princeton University, Princeton, New Jersey. Received July 15, 1964

The ring-chain equilibrium of liquid sulfur was previously studied by Tobolsky and Eisenberg. In this earlier theory, an assumption was made about the length of the polymer molecules. In this present paper this assumption is removed and the new theoretical results are compared with the previous ones.

Polymerization of Liquid Sulfur

The first relatively complete theory of the equilibrium polymerization of liquid sulfur was given by Gee.² This theory was characterized by the use of two distinct treatments: one valid below the transition temperature and one valid above the transition temperature. Tobolsky and Eisenberg³ later presented a unitary theory valid above and below the transition temperature. It actually predicted the transition. This theory was perfectly consistent with the results of Gee; in fact it used the results of Gee as experimental data from which to evaluate numerically the pertinent equilibrium constants. The theory is also in accord with early statistical calculations of ring-chain equilibria.⁴

The Tobolsky-Eisenberg theory was based on the following chemical reactions

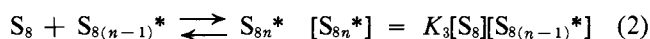
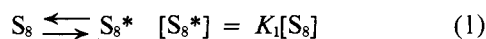

where the asterisk indicates chain molecules and the only nonpolymer molecule is supposed to be the eight-membered ring. With the help of these equations and a straightforward application of the theory of chemical equilibria, the weight concentration of polymers as

(1) (a) Technological University; (b) University of California; (c) Princeton University.

(2) G. Gee, *Trans. Faraday Soc.*, **48**, 515 (1952).

(3) A. V. Tobolsky and A. Eisenberg, *J. Am. Chem. Soc.*, **81**, 780 (1959).

(4) H. Jacobson and W. H. Stockmayer, *J. Chem. Phys.*, **18**, 1600 (1950).

well as the mean chain lengths was expressed in terms of K_1 and K_3 .

It is obvious that eq. 2 can be replaced by eq. 2a without any change whatever in the theory or its results.

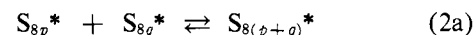

$$[\text{S}_{8(p+q)}^*] = K_5[\text{S}_{8p}^*][\text{S}_{8q}^*]$$

$$(p, q = 1, 2, 3, 4, \dots)$$

The relation between K_5 , K_3 , and K_1 is

$$K_3 = K_1 K_5 \quad (2b)$$

Though this theory gave an essentially correct picture of the polymerization of sulfur, its basis as given by eq. 1 and 2 or 2a contains the assumption that the number of atoms in all the molecules can only be multiples of eight.

It is possible to write alternative equations where this assumption is avoided. Consider the relations

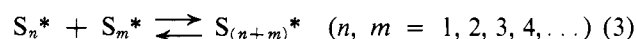

$$[\text{S}_{(n+m)}^*] = \bar{K}_5[\text{S}_n^*][\text{S}_m^*]$$

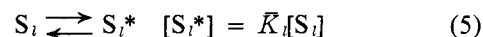
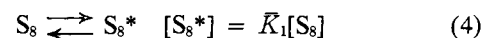

Equation 3 is analogous to one used earlier by Gee, in that it expresses the assumption that in the polymeric molecules, units of eight do not have an exceptional position. Equation 5 accounts for the possibility of other than the eight-membered ring.

Inasmuch as eq. 3-5 represent a physical model for the equilibria, differing from the basis of eq. 1-2b, it is advisable to distinguish between the constants K_5 and \bar{K}_5 , and K_1 and \bar{K}_1 . The final evaluation of the equilibrium constants is achieved by comparing the theoretical equations from either model with the ex-